

Dear users,

Thanks for your support and credit of our company. Please read this manual instruction carefully before installing and operating. If you have any problems, please contact us, we will answer it in time.

Safe regulations (Important)

Please install an air switch with leakage current prevention.



It may lead to electric shock, fire and physical hurt.

Please connect the ground clamp of the power pin with earth reliable.



It may lead to electric shock, equipment damage or fire.

If any problem occurs, please switch off and check the equipment, then restart.



It may lead to electric shock, and equipment damage .

Don not dive hands into fan laminae.

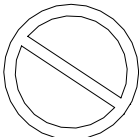

It may lead to physical hurt.

Don not disassemble the equipment by self.

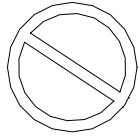

It may lead to equipment damage.

Don not jam the heat aperture and put anything on the equipment.

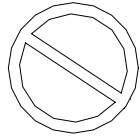

It may lead to equipment damage.

1. Package

☺ Unpacking:

Check the items according to the encasement list within package. If any problem occurs or item misses, please contact us as soon as possible.

☺ Check equipment type

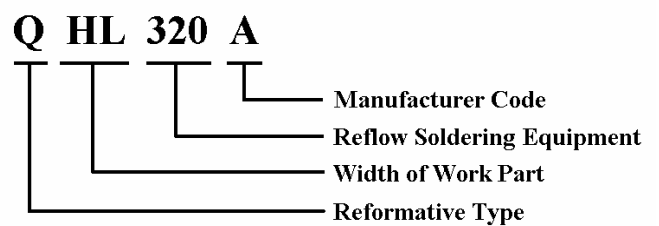

2. Outline

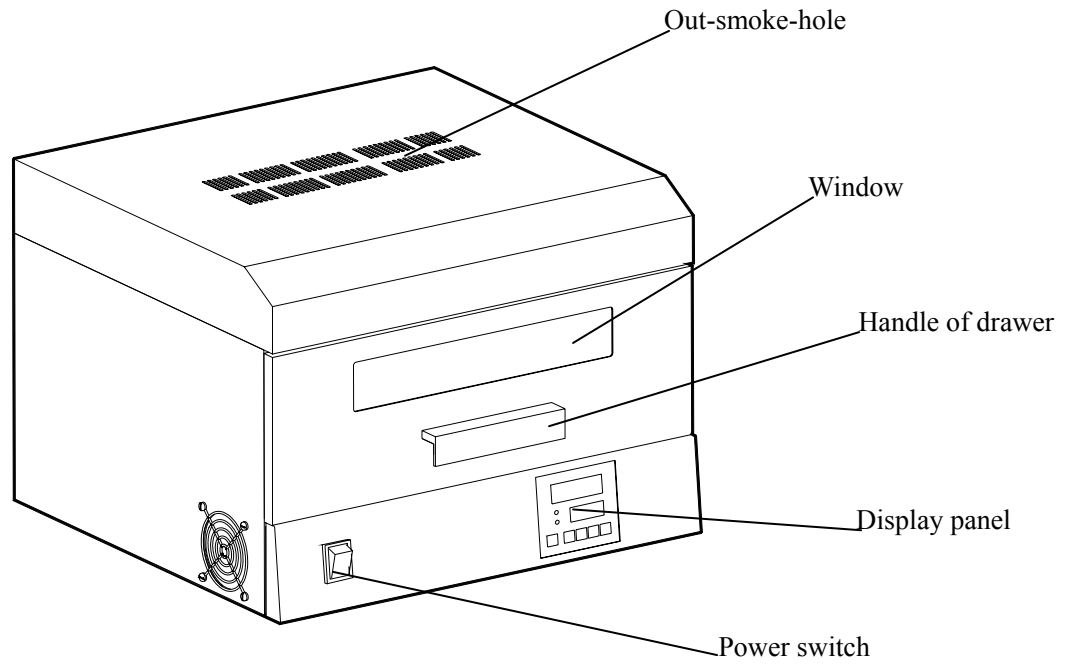

Picture1 Front View

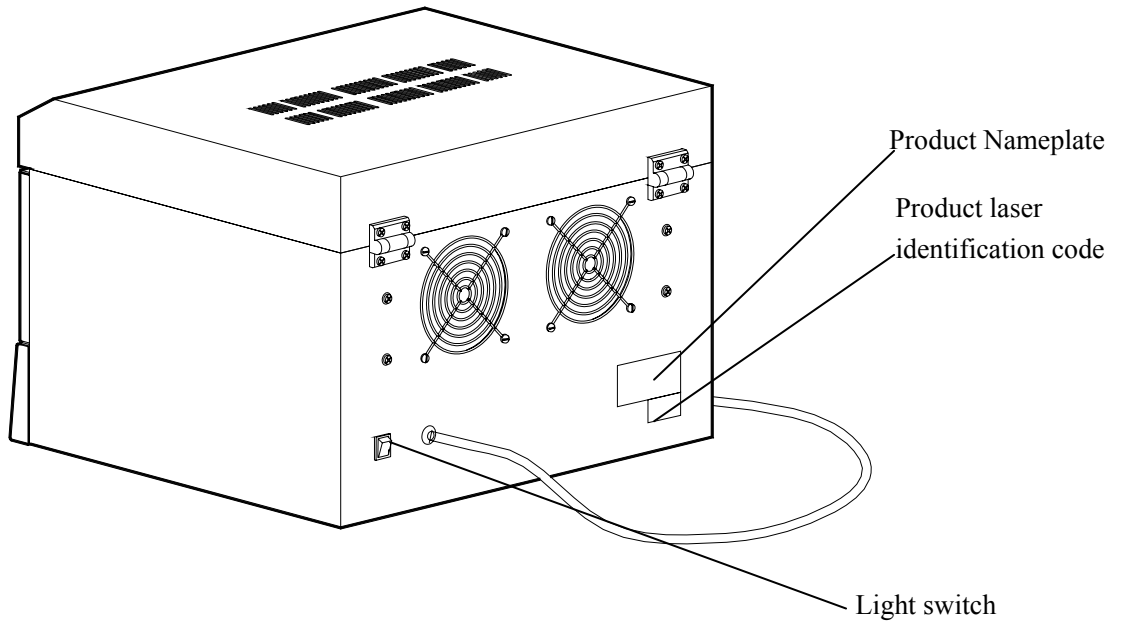

Picture2 Back View

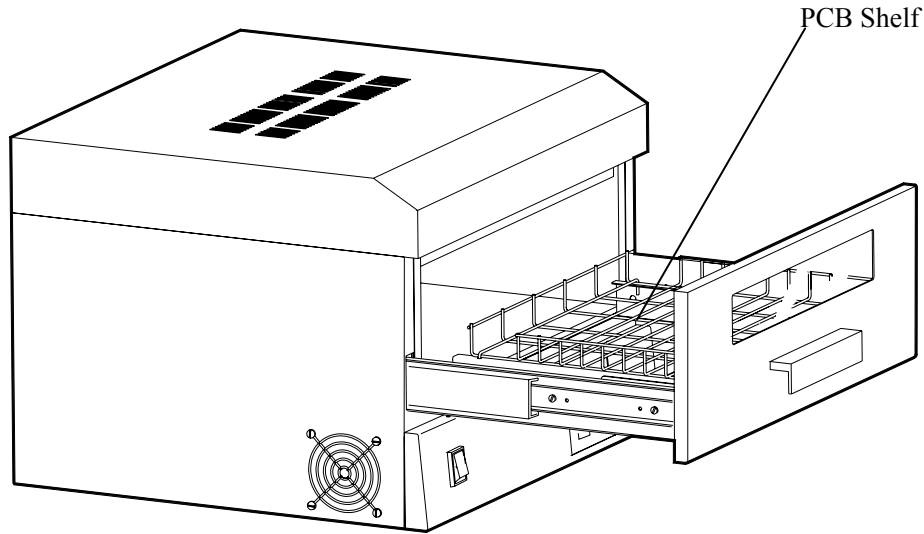

Picture3

3. Installation

☺ Environment conditions:

- ☼ Please avoid installing in the place around dust, corrosion gas, damp, leakage rain, high temperature, electromagnetism, and strong RF emission, shaking and rocking.
- ☼ Please keep the equipment away from flammable, explosive, volatile items, and strong convective air, and keep enough space for operating and servicing that are convenient for maintaining and cleaning.

☺ Placement conditions:

Please place the equipment flatly on a wooden or a steel workbench (please connect to ESD ground line).

☺ Temperature conditions:

Environment temperature: 10~30°C

Environment humidity: ≤85%RH

☺ Power conditions:

- A. Please install a single-phase air switch of which the capacity is $\geq 15A$ with leakage current protection.
- B. Power of equipment is AC220V single-phase three lines with PE protection.
- C. Please measure up the grounding resistance,

while using PE as a ESD ground line.

- D. Please use a plug receptacle of which the rating current is $\geq 15A$ for equipment.

4. Operation

☺ Before start

- ☼ Please confirm the supply power is congruous with the product nameplate.
- ☼ Please connect the grounding wire with grounding equipment reliably.
- ☼ Please clean the equipment inside.

☺ Start

Press the power switch of the equipment, self-check is loading firstly. After self-check, window1 (Picture4) displays “ PASS ” and current temperature later. Window2 (Picture4) displays time “ 00 ”.

☼ [SET] key: sound alarms each press. Setting alert temperature in default temperature curve, the startups segment of cooling (any of 20 segments can be set as cooling startup), and time and temperature of each segment.

☼ [Run/Stop] key: sound alarms each press. Setting back, program running and stop.

☼ [◀] Back key: sound alarms each press.

☼ [▲] Increment set key: +1 per press.

☼ [▼] Decrease set key: -1 per press.

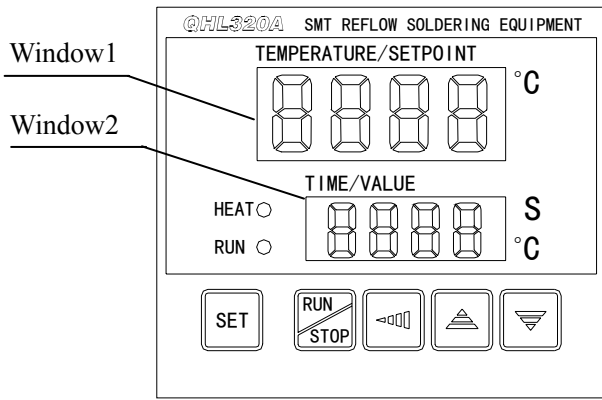

Picture4 Display panel

☺ **Preferences**

✧ Picture5 Typical PCB reflow soldering temperature curve

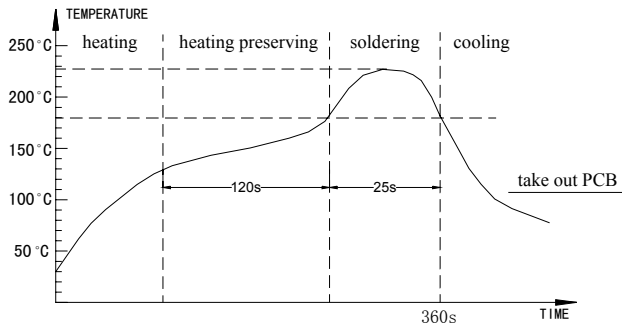

Picture5

The temperature curve is the key to control soldering effect. Real-time temperature curve should be set congruously with the temperature curve of solder paste. The speed of heating should be set between 1-2°C/s before 160°C. If speed is too fast, on the one hand, it makes SMD and PCB heated too fast that leads to components damage and PCB distorted. On the other hand, it makes the flux of solder paste volatilized too fast that leads to metallic components spilling, which engenders solder balls. Generally, set peak value of temperature 20~40°C more than that of solder paste and reflow soldering time between 10~60 seconds. If set peak value too low or reflow soldering time too short, it leads to soldering deficiently, or results in infusible solder paste. Moreover, if set peak value too high or reflow soldering time too long, it leads to metallic components oxygenated that impacts soldering effects, or even results in SMD and PCB damage.

Reflow soldering temperature curve sets

- a. According to the temperature curve of solder paste, which is various temperature curve based on metallic content. Please set the reflow soldering temperature curve according to the temperature curve of solder paste offered by the solder paste suppliers.
- b. According to the material, thicknesses, ply, and dimension of PCB.
- c. According to the density, size, and color of SMD on PCB, and whether there are special SMD, i.e., BGA, CSP.
- d. Fast heating system is adopted in the equipment. Please set temperature a little lower than real temperature cause difference exists between real temperature and displayed temperature.
- e. According to different technologic demands, we offer three heating technologic curves, which can be modulated in the equipment. The first curve (Ln1) is default that is suited for some PCB soldering. It is recommended that users do not modify the first curve. Each curve is segmented in 20 sections; users can set the temperature and time of each section according to technologic demands. The max temperature of each section is 260°C, and the running time of each section is 9999 seconds.

(1) Set temperature curve

Press [SET] key on the panel, window1 displays “Ln”, window2 displays “1”, “2” or “3” is available by pressing [▲] and [▼].

- 1 means the first temperature curve
- 2 means the second temperature curve
- 3 means the third temperature curve

(2) Set imperative cooling section

Press [SET] key, window1 displays “Fn”, window2 displays current section, press [▲] and [▼] to choose any of 1~20 section, in which the cooling start, and this is the end section. After the end section, the equipment alarms.

(3) Set temperature alert

Press [SET] key, window1 displays “AL”; window2 displays the upper limit of temperature (normal is 240 °C).

(4) Factory Test (For manufacturer test)

Press [SET] key, window1 displays “DIS”, window2 displays “9999”, press [▲] and [▼] to

modify.

(5) Set temperature and time of each section

☀ Set temperature

Press [SET] key, window1 displays “C01” (C means temperature, 01 means the first section), window2 displays the temperature value of the first section. Press [▲] and [▼] to modify.

☀ Set time

Press [SET] key, window1 displays “t01” (t means time, 01 means the first section), window2 displays the time value of current section. Press [▲] and [▼] to modify.

(6) Repeat Step (5) to set other sections. Press [◀] to previous section. Press [RUN/STOP] key to stop setting and back to start.

(7) Set temperature and time of cooling section

☀ Set temperature

Press [SET] key, check whether the section displaying in window1 is as same as set in Step (2), window2 displays the temperature value which is “00” set in cooling section. Do not modify temperature of cooling section.

☀ Set time

Continue pressing [SET] key, check whether the section displaying in window1 is as same as set in Step (2), window2 displays the time value in current section. Press [▲] and [▼] to modify.

Press [RUN/STOP] key to stop setting and back to start. Window1 displays the current temperature value, window2 displays time 00 (s).

(8) Repeat Step (1) ~ (7) to modify if users need.

While re-setting, press [◀] to back. All sets are stored in memory automatically, which is default at next start.

Appendix

Set typical reflow soldering curve (Curve 1): (Preferences details in attachment1)

Step 1: Press [SET] on panel, window1 displays “Ln”, window2 displays: “1”, which means the first temperature curve.

Step 2: Continue pressing [SET], now window1 displays “Fn”, window2 displays current section. Press [▲] and [▼] to change the value displayed in window2 to 20, which means the first temperature curve is segmented in 20 sections, the cooling section

starts at the 20th section and is the ending section.

Step 3: Continue pressing [SET], window1 displays “AL”, window2 displays the upper limit of temperature. Press [▲] and [▼] to change the number displayed in window2 to 230, which means the equipment alarms when the temperature reaches to 230°C.

Step 4: Continue pressing [SET], now window1 displays “DIS”, window2 displays “9999”. Users need not to set in this step.

Step 5: Continue pressing [SET], now window1 displays “C01”, window2 displays the temperature value set in the first section. Press [▲] and [▼] to change the value displayed in window2 to 70, which means the highest temperature in the first section.

Step 6: Continue pressing [SET], now window1 displays “t01”, window2 displays the time value set in current section. Press [▲] and [▼] to change the value displayed in window2 to 25, which means the temperature will reach to 70°C in 25 seconds.

Step 7: Continue pressing [SET], now window1 displays “C02”, window2 displays the temperature value set in the first section. Press [▲] and [▼] to change the value displayed in window2 to 80, which means the highest temperature in the second section.

Step 8: Continue pressing [SET], now window1 displays “t02”, window2 displays time value set in current section. Press [▲] and [▼] to change the value displayed in window2 to 15, which means temperature will reach to 80°C in 15 seconds.

Step 9: According to step 5 and 6, set temperature and time of 3~19 section refer to attachment1.

Step 10: The 20th section is cooling section, in which the temperature cannot be set but time can be. Refer to attachment1; value of “t20” is 120.

Step 11: Press [RUN/STOP] to finish the first curve set.

☺ Load original set

Turn off the equipment and shut off the power, then press [RUN/STOP] and [▼] simultaneously and hold until window1 displays “----” and the buzzer phonates, then window1 displays “PASS”. Original set loading is finished.

Details of original set in attachment1.

☺ Run

Press [RUN/STOP], now the running indicator light (green) brightens up and heating indicator light (red) brightens up, which means quartz's tube output. Window1 displays current section and temperature alternately. Window2 displays running time of each section (s1~20, means which section). If user wants to stop, press [RUN/STOP] to stop running, and then all indicator lights turn off. After all sections are finished, the buzzer phonates, while the cooling electromachine is remaining. Window1 displays current temperature inside the equipment. Press [RUN/STOP] to stop phonating, cooling electromachine stops. Press [RUN/STOP] again; the equipment will work from the first section.

Suggestions: Please run the equipment to warm up before use it each time.

- A. During the equipment is running, it is forbidden to modify other temperature curve.
- B. Do not exceed the soldering area $320*220\text{mm}^2$, while placing the PCB. Please keep PCB flat.
- C. Please open the drawer slowly to avoid PCB shaking, which make SMD shift.
- D. Please keep watching when the equipment is running.
- E. Please do not touch the part exposed in front of temperature sensor.

☺ Shut down

Shut off the power after work.

5. Maintain

It is very important for the equipment to maintain timely.

☺ Clean

After the equipment has been used for a period, there is some volatile matter left on the surface inside, which impact the equipment running. Please clean it. Shut down the equipment; use alcohol to clean inside and outside it. It is forbidden to use strong corrosive.

☺ Maintain sensor

The sensor is located on top of the quartz tube. Please do not strike the probe of the sensor. Please use water-free alcohol tampon wipe it softly to clean.

Caution: Do not shift the probe while cleaning.

☺ Check the power

Please make sure that the connection of power is tried before start.

☺ Heating fault

Please check the quartz tube when the equipment has finished working based on the right temperature curve, solder paste is not yet solidified entirely. If any tube is broken, please change a new one (it should be the same).

Caution: Only professionals are permitted to change the quartz tube.

Methods: (Picture 6 and 7)

- a. Please keep the equipment working, observe which quartz tube does not light.
- b. Please shut down, when the equipment is cooling down, open the drawer, and screw the bolts off on the cover. Open the cover; screw the porcelain cap in both sides of the quartz tube and the nuts.
- c. Please take out the quartz tube, change the new one by the contrary order of (b).
- d. Please put down the cover and start, observe the equipment.
- e. Caution: Please make sure the equipment is cooling, and use a fixture spanner. Please do not damage the insulator.

☺ Turn on power, the equipment does not display or fans do not work

Check the connection of power. If power supply is working, please call professionals for help and support.

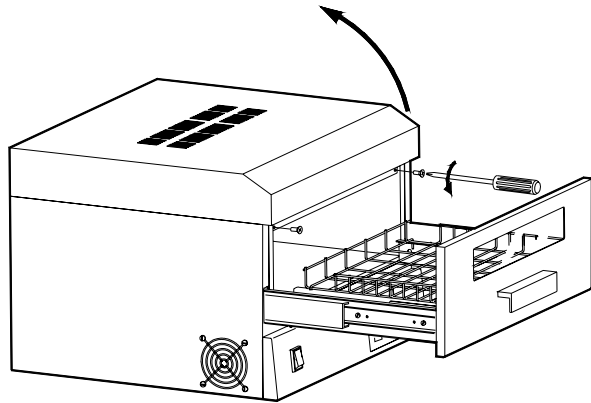

Picture6

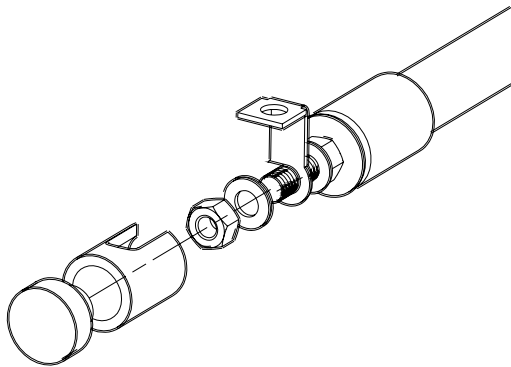

Picture7

- 9. Width: 320mm
Max PCB: 320*220 mm²
- 10. Dimension: 490*450*345 mm³
- 11. Weight: 32Kg

Attachment1

QHL320A Factory Set

Press [SET] continuously, the panel displays:

Ln	1
Fn	20
AL	230
DIS	9999

C01	70	t01	25
C02	80	t02	15
C03	85	t03	05
C04	90	t04	05
C05	95	t05	05
C06	100	t06	05
C07	105	t07	05
C08	110	t08	05
C09	115	t09	05
C10	120	t10	05
C11	125	t11	05
C12	130	t12	10
C13	135	t13	10
C14	140	t14	10
C15	145	t15	20
C16	150	t16	20
C17	155	t17	25
C18	160	t18	25
C19	205	t19	50
C20	00	t20	120

☺ **Fans Fault**

Please shut off the power, open the cover, and check whether the fans strike the equipment. If it exists, please adjust the location of the fans.

☺ **Smell**

Please check the temperature set that is too high that leads to PCB carbonized, or other stuff leave inside.

6. Technologic parameter

- 1. Rated voltage: AC 220V (with PE)
- 2. Rated frequency: 50Hz
- 3. Rated power capability: <3.3KW (Average=1.0KW)
- 4. Temperature upper limit: 260°C
- 5. Environment temperature: 10~30°C
- 6. Working temperature: 40~230°C
- 7. Light inside: 220V/35W
- 8. PCB automatic soldering time: 4~6min
Continuous working time: 48H